

Organizado por:



A beneficio de:



Colabora:



Patrocinado por:



II-DUATLÓN SOLIDARIO UTEBO

Modalidad:

CROSS

26 de febrero de 2012

Plaza Ayuntamiento

11:00 horas



Más información en: ccutebo.blogspot.com // www.clubciclistautebo.es // clubtriatlonutebo.blogspot.com



III-DUATLÓN SOLIDARIO UTEBO



DISTANCIAS

1º SEGMENTO – Carrera a pie

5,9 Km

(1 vuelta casco urbano + 2 vueltas parque Espacio Joven)

Asfalto + Tierra compactada

2º SEGMENTO – Ciclismo BTT

19,25 Km

(1 vuelta huerta-dehesa del Ebro)

Asfalto (enlace) + Pista

3º SEGMENTO – Carrera a pie

2,67 Km

(1 vuelta parque Espacio Joven)

Tierra compactada



II-DUATLÓN SOLIDARIO UTEBO



HORARIOS

DOMINGO, 26 de Febrero de 2012

9:45	Reunión Técnica
10:00	Apertura Área Transición
10:45	Cierre Área Transición
10:50	Cámara de llamadas masculina
11:00	SALIDA MASCULINA
11:00	Cámara de llamadas femenina
11:03	SALIDA FEMENINA



II-DUATLÓN SOLIDARIO UTEBO



1ª Segmento : 1ª Vuelta por Casco Urbano

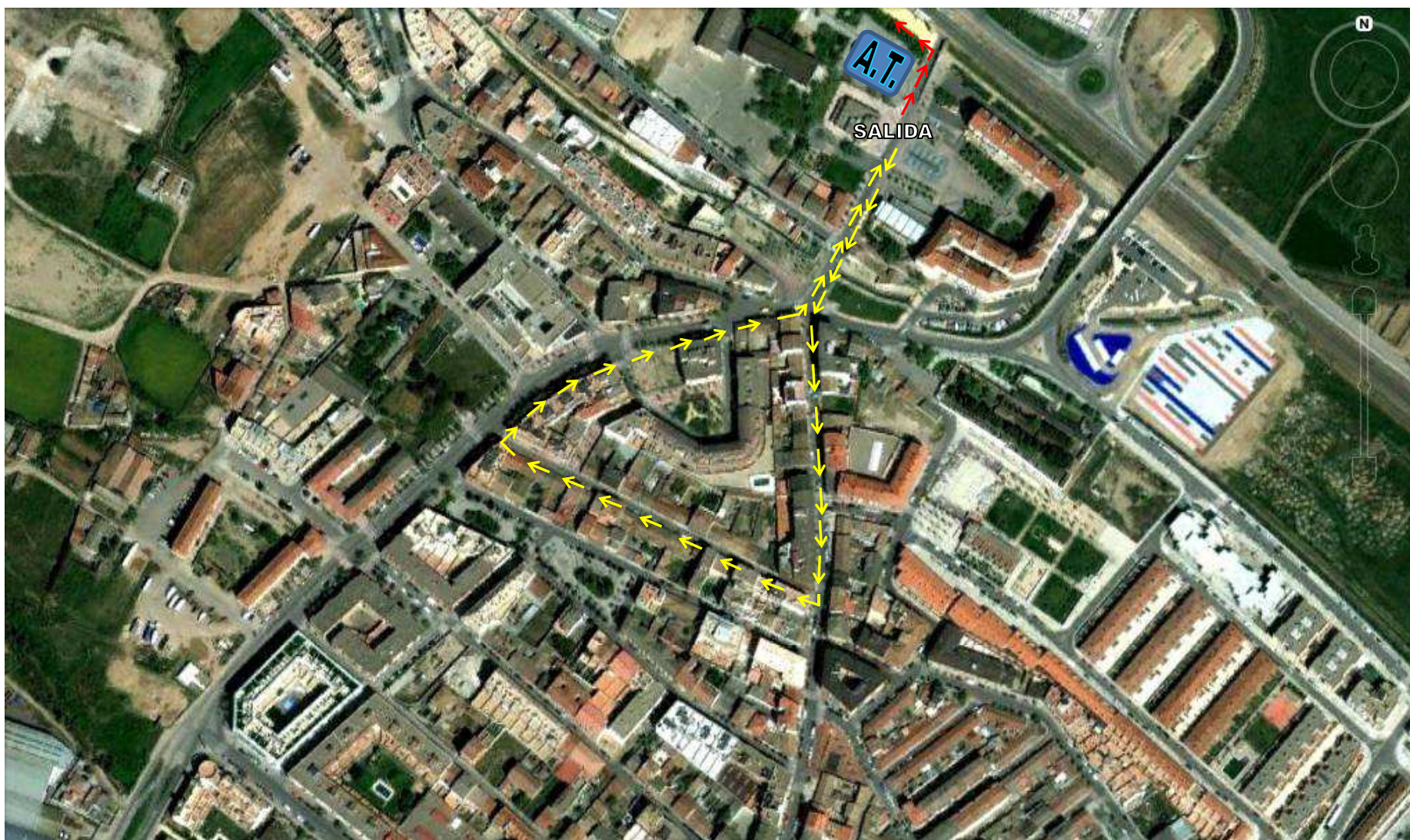



HI-DUATLÓN SOLIDARIO UTEBO

1ª Segmento : Inicio de 3ª Vuelta

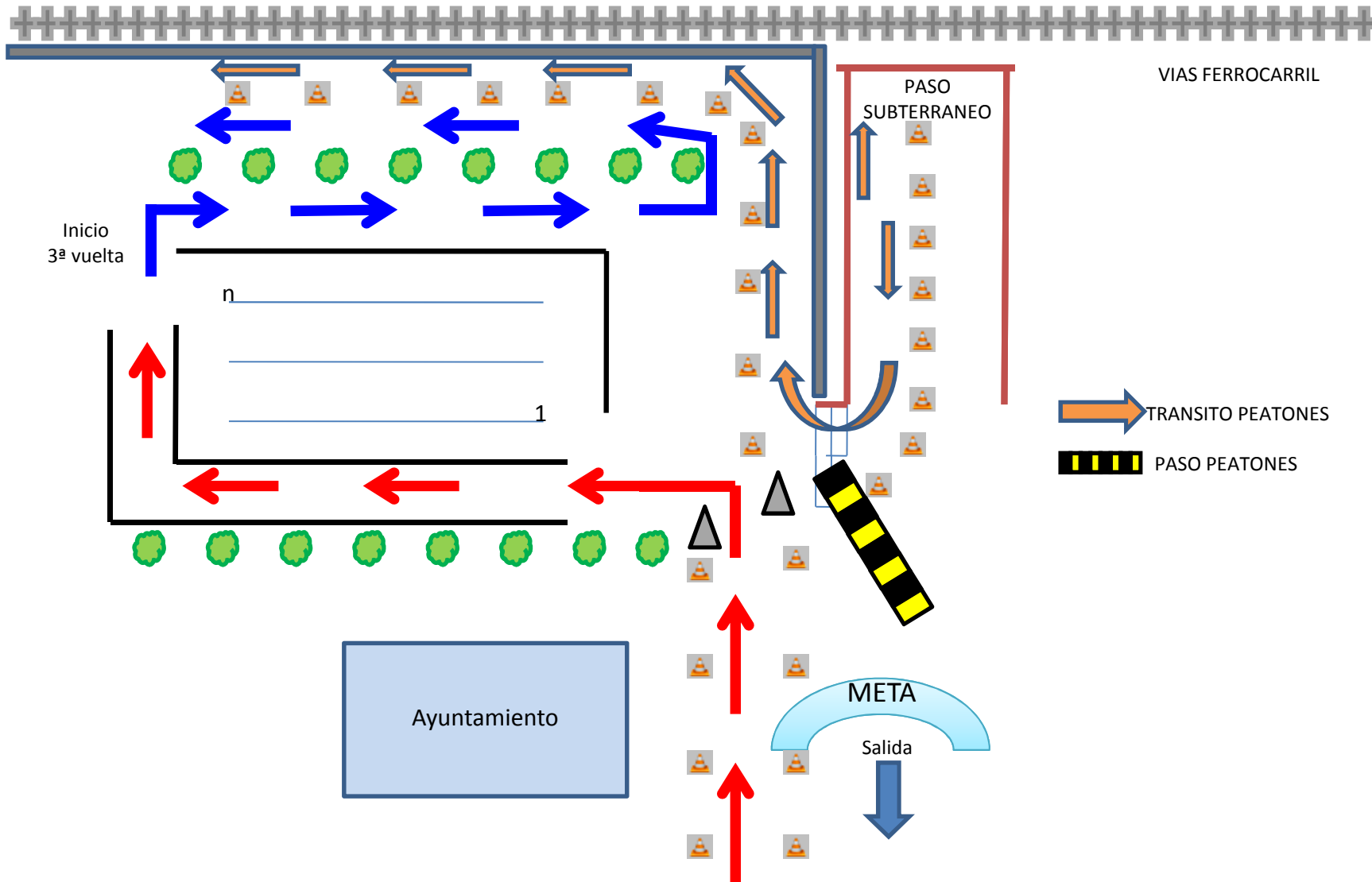

Inicio 3ª vuelta

n

1

Ayuntamiento

META

Salida

VIAS FERROCARRIL

PASO SUBTERRANEO

TRANSITO PEATONES
PASO PEATONES



II-DUATLÓN SOLIDARIO UTEBO

1ª Segmento : 3ª Vuelta





TRIA- DUATLÓN SOLIDARIO UTEBO

1ª TRANSICIÓN

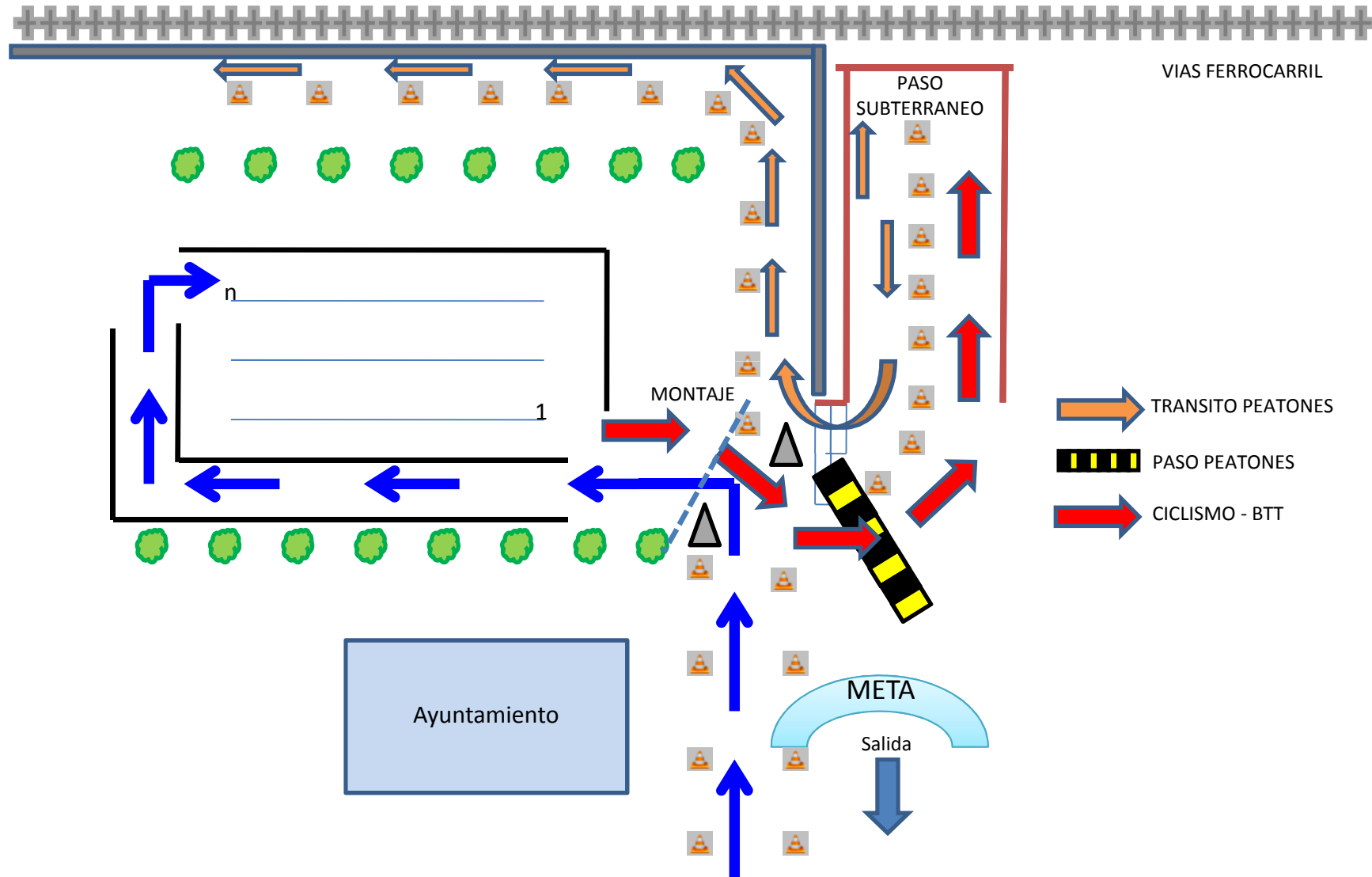



II-DUATLÓN SOLIDARIO UTEBO

Desplazamientos por Área Transición

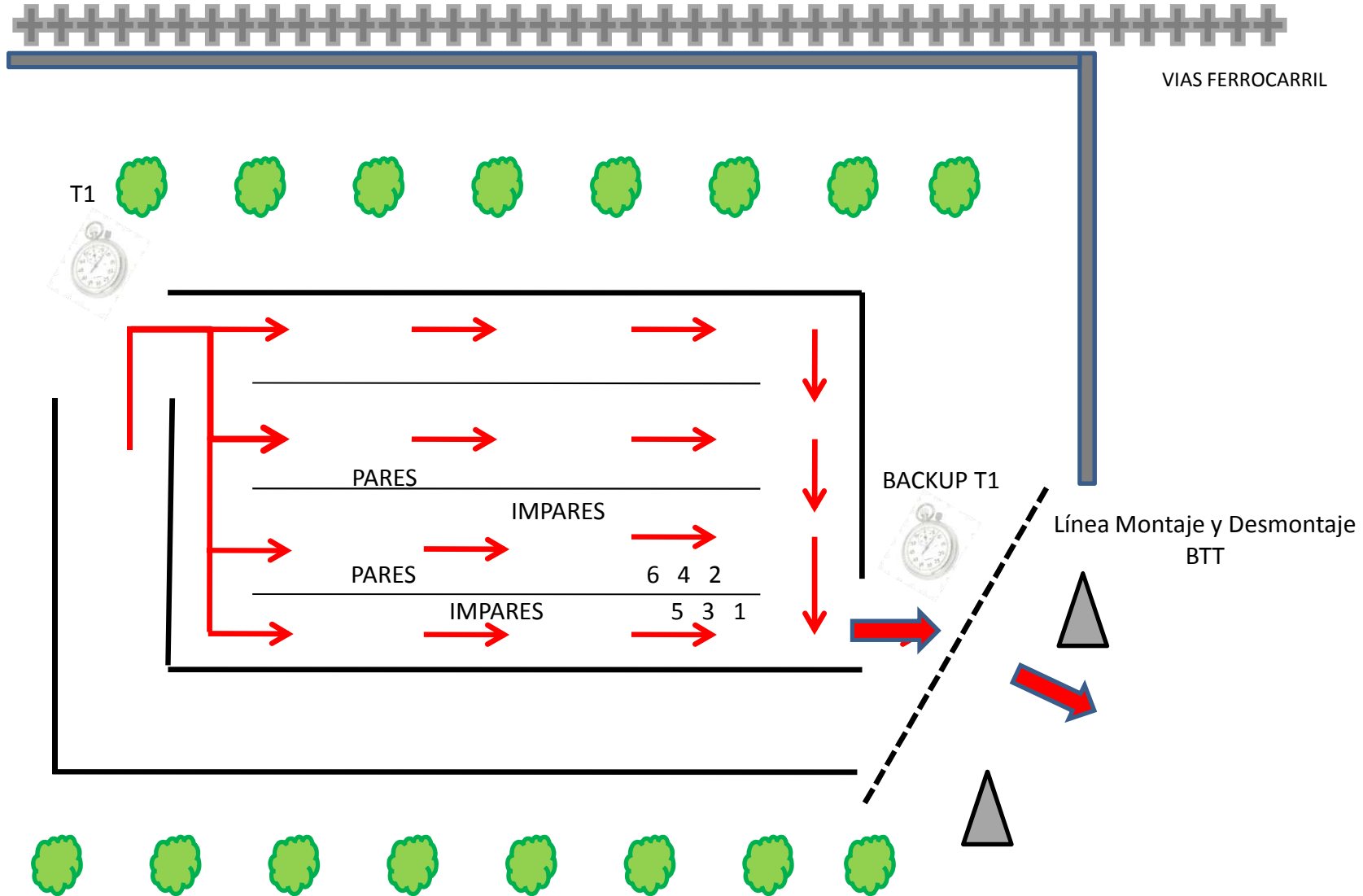



II-DUATLÓN SOLIDARIO UTEBO

Ciclismo BTT





II-DUATLÓN SOLIDARIO UTEBO

2ª TRANSICIÓN

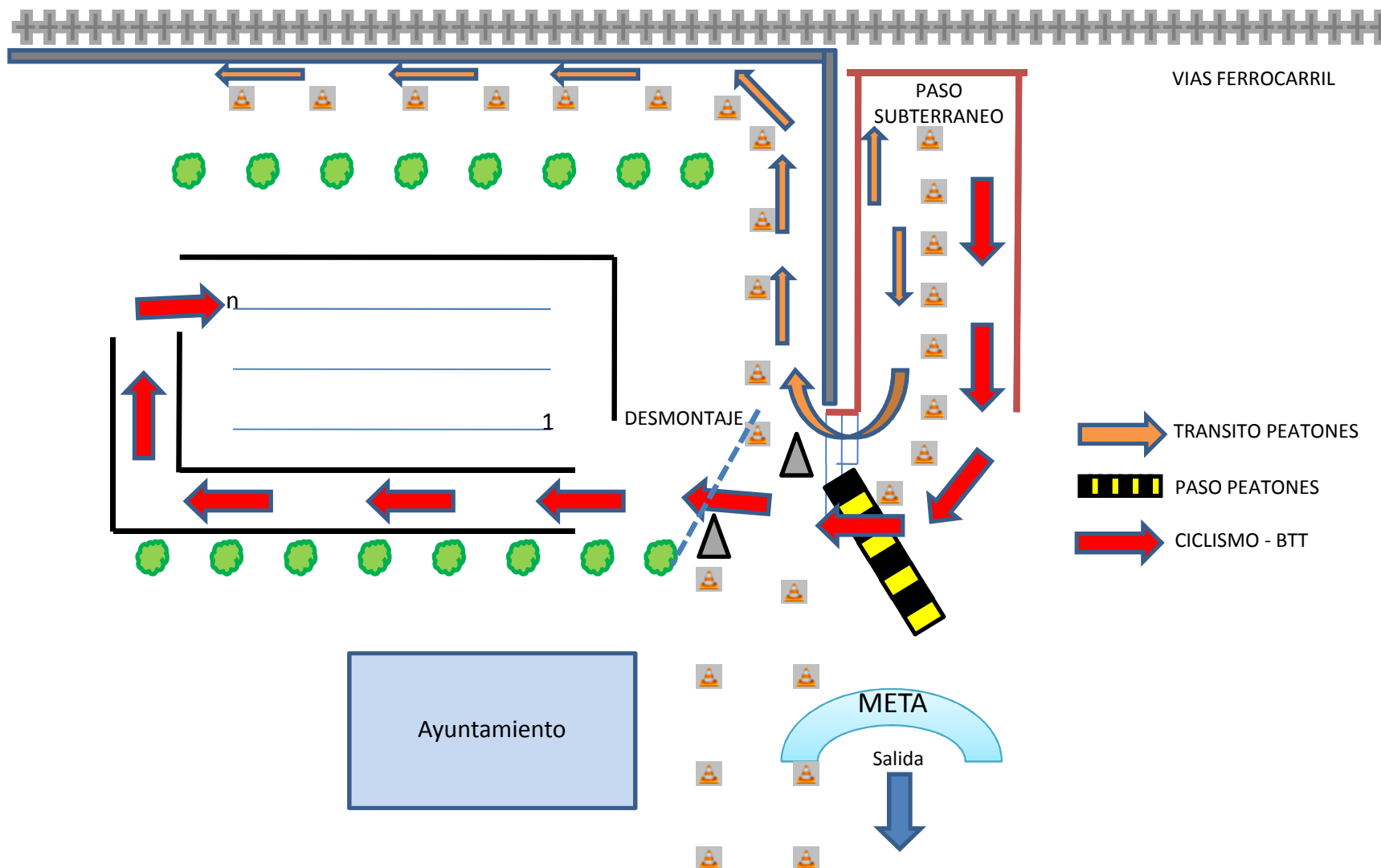



II-DUATLÓN SOLIDARIO UTEBO

Desplazamientos por Área Transición

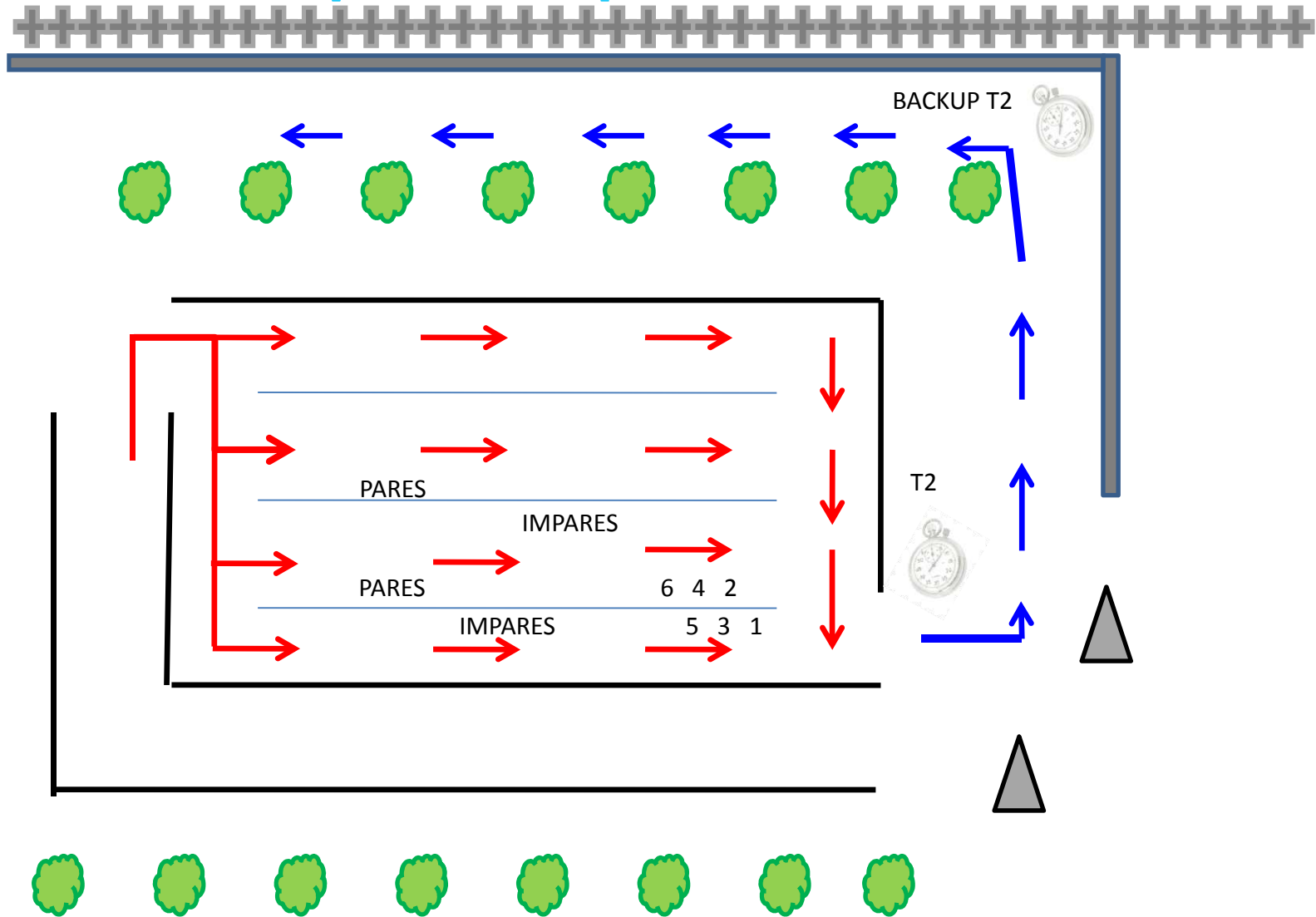



II-DUATLÓN SOLIDARIO UTEBO

3ª Segmento : Vuelta





TRIDUATLÓN SOLIDARIO UTEBO

ENTRADA EN META

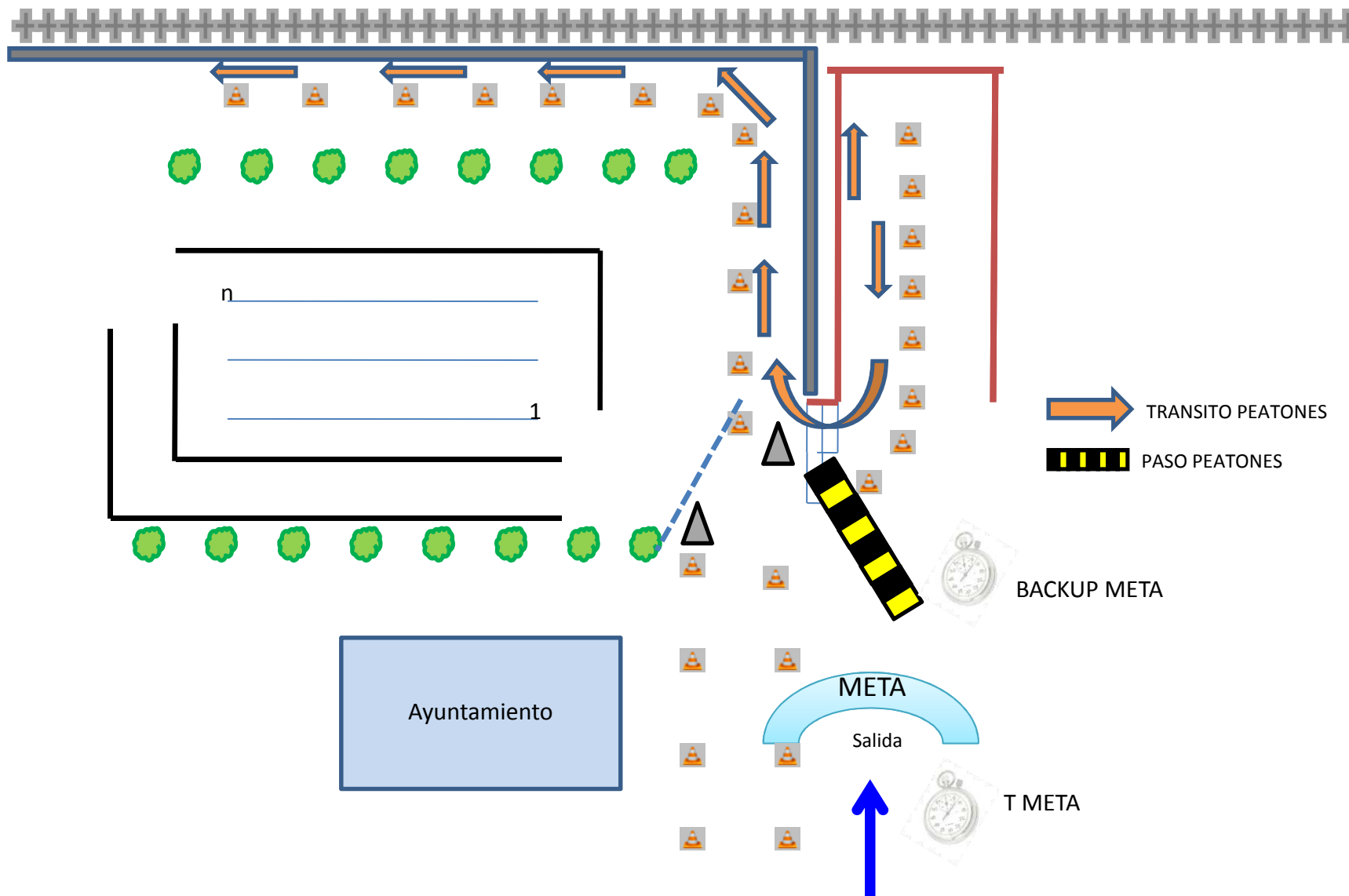



III-DUATLÓN SOLIDARIO UTEBO

SERVICIOS



II-DUATLÓN SOLIDARIO UTEBO

A BENEFICIO DE

AFEDAZ

Asociación de Familiares
de Enfermos de Alzheimer

